

# 2275FSi

Specifications:		2-25" Tubes	Express Pkg	2 - Ellip Tubes	3- 25" Tubes	ESP Pkg	
LOA.....	24' 2"	Max. HP Capacity.....	150 hp	150 hp	150 hp	225 hp	250 hp
Pontoon Length.....	22' 6"	Approx. Hull Weight.....	2244 lbs	2244 lbs	2394 lbs	2724 lbs	2799 lbs
Deck Length.....	21' 11"	Person Capacity.....	13/1762 lbs	13/1762 lbs	13/1762 lbs	12 / 1680 lbs	14 / 1920 lbs
Deck Width.....	8' 6"						
Pontoon Diameter.....	25"						
Pontoon Gauge.....	0.08"						

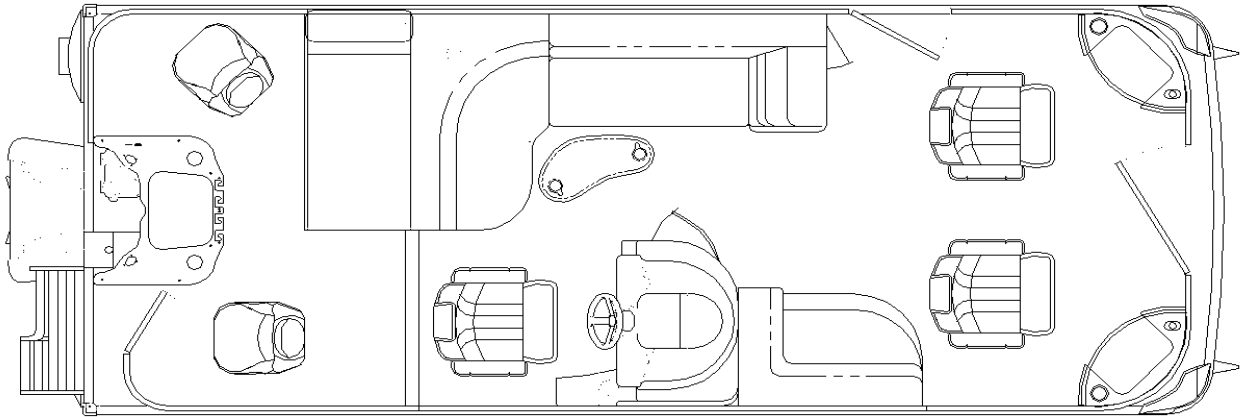

## Standard Features

### Exterior

- 10' Bimini Top w/ Embroidered Boot, Quick Release Fittings & 1.25" Frame**
- 24" tall front rails**
- 25" pontoons
- 6" stainless steel cleats
- Anodized, raised rails for drainage
- Bimini trailer struts
- 16" on-center main cross members**
- Curved Fisher Bow**
- Docking lights with color matched housings**
- Full length pontoon skirting
- Panels to top rail**
- Playpen cover - Surlast**
- Rail system - Angled top rail verticals**
- Seat hinges powder coated Java**
- Stainless deck bolts
- Stainless steel ring cup holders**
- Stainless steel corner castings
- Stern entry platform & ladder
- Underdeck spray deflectors

### Interior

- Aft vinyl floor**
- 2 Bow Boxes**
- 2 Bow Recliners on sliders**
- 2 Rear Deluxe Bass Seats**
- 31 Gallon center mounted fuel tank
- Captain's Reclining helm seat with swivel/slider**
- Fire extinguisher
- Fish Station**
- High Performance Palm Carpet**
- Livewell w/Bait Bucket (in bench forward of console)**
- Lockable rod storage
- Kidney shaped table
- Privacy enclosure

### Console

#### 41" Console

- Locking glovebox
- Lockable side access storage w/ soft cooler
- Mahogany panel
- Tachometer, fuel and trim gauges
- 12 volt receptacle
- Flush mounted Garmin fish graph
- Helm courtesy light
- Rocker switches w/dash mounted breakers
- Sony GT Series CD - MP3, 4 speakers with color matched speaker grills**
- Tiger polished steering wheel**
- Tilt steering**
- Windshield