

2275GSi

Specifications:		<u>2-25" Tubes</u>	<u>Express Pkg.</u>	<u>2 - Ellip Tubes</u>	<u>3- 25" Tubes</u>	<u>ESP Pkg</u>
LOA.....	24' 2"	Max. HP Capacity.....	150 hp	150 hp	150 hp	225 hp
Pontoon Length.....	22' 6"	Approx. Hull Weight.....	2244 lbs	2244 lbs	2394 lbs	2724 lbs
Deck Length.....	21' 11"	Person Capacity.....	13 / 1762 lbs	13 / 1762 lbs	13 / 1762 lbs	12 / 1680 lbs
Deck Width.....	8' 6"					
Pontoon Diameter.....	25"					
Pontoon Gauge.....	0.08					

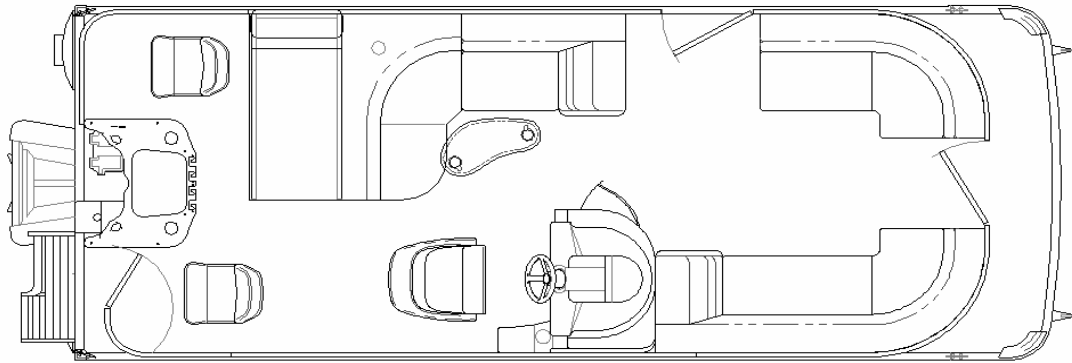

Standard Features

Exterior

10' Bimini Top w/ Embroidered Boot,
Quick Release Fittings & 1.25" Frame
 25" Pontoons
 6" Stainless Steel Cleats
 Anodized, Raised Rails for Drainage
 Bimini Trailer Struts
16" On-center Main Cross Members
Docking lights with color matched housings
 Full Length Pontoon Skirting
 Large Radius Bow Rails with 24" Bow Gate
Panels to top rail
Playpen Cover - Surlast
Rail system - Angled top rail verticals
Seat hinges powder coated Java
 Stainless Deck Bolts
 Stainless Steel Corner Castings
Stainless Steel Ring Cup holders
 Stern Entry Platform & Ladder
 Underdeck Spray Deflectors

Interior

2 Stern Fishing seats
 2 Chaise Lounge w/Storage
 31 Gallon Center Mounted Fuel Tank
 Captain's Seat w/ Slider / Swivel
 Fire Extinguisher
High Performance Palm Carpet
 Kidney Shaped Table
 Privacy Enclosure
 Stern Fish Station w/Livewell, Cupholders & Rod Holders
Stern vinyl floor

Console

41" Console
 12 Volt Receptacle
 Faria Gauges w/ Sealed Connectors
 Helm courtesy light
 Instrumentation: Mahogany Panel
 Includes: Tachometer, Trim,
 & Fuel Gauge
 Lockable Console Door

 Rocker Switches w/dash mounted breakers
 Soft Cooler
Sony GT Series CD - MP3, 4 speakers
 w/ color matched speaker grills
Tiger polished steering wheel
Tilt Steering
 Windshield