

# 24 SFi

Specifications:		25" Tubes	Express Pkg.
LOA.....	23' 8"	Max. HP Capacity.....	150 hp
Pontoon Length.....	22' 6"	Approx. Hull Weight.....	1860 lbs
Deck Width.....	8' 6"	Person Capacity.....	13 / 1762 lbs
Pontoon Diameter.....	25"		13 / 1790 lbs
Pontoon Gauge.....	0.08"		

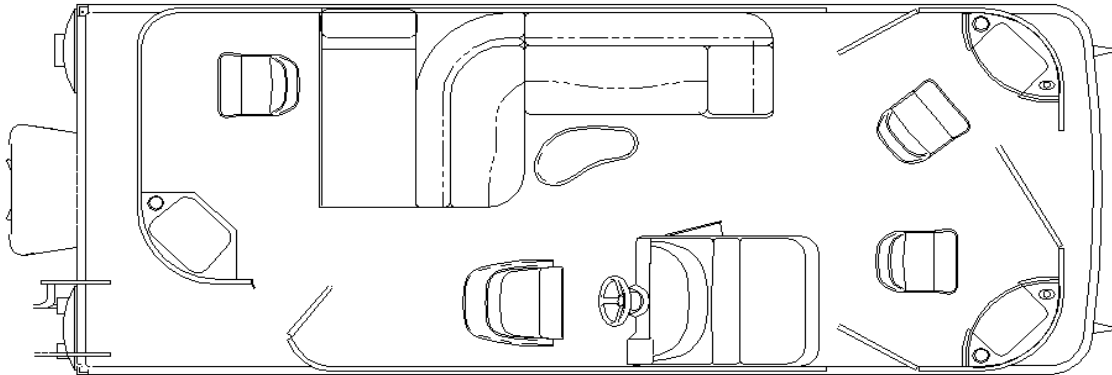

## Standard Features

- 24 Gallon Transom Fuel Tank
- 25" Pontoons
- 3 Fishing Seats
- 4 Pole Rod Holder**
- 6" Stainless Steel Cleats
- 8.5' x 10' Bimini w/Boot - Surlast**
- Anodized, Raised Rails for Drainage
- Bimini Trailering Struts
- Captain's Seat w/ Slider / Swivel
- Fire Extinguisher
- Full length skirting**
- High Performance Palm Carpet**
- Kidney table**
- Playpen Cover - Surlast**
- Port Bow Livewell**
- Rail system - Angled top rail verticals**
- Seat hinges powder coated Java**
- Stainless Deck Bolts
- Stainless Steel Corner Castings
- Stainless Steel Ring Cup holders**
- Starboard Bow Storage**
- Stern Entry Platform & Ladder
- Stern Livewell**
- Stern Storage Closet with optional privacy**
- Underdeck Spray Deflectors
- Upgraded Graphics Package in Java**

## Console Features:

- 12 Volt Receptacle (15 Amp)
- Majestic Burl Dash**
- Faria Gauges
- One piece fiberglass fishing console**
- Instrumentation Includes:
  - Tach, Fuel & Trim Gauges
- Lockable Console Door
- Rocker Switches w/dash mounted breakers
- Soft Cooler
- Sony GT Series CD - MP3, 4 speakers**
- w/ color matched speaker grills**
- Tiger polished steering wheel**