

# 20 SFi

<b>Specifications:</b>			<u>23" Tubes</u>	<u>25" Tubes</u>
LOA.....	19' 8"	Max. HP Capacity.....	60 hp	60 hp
Pontoon Length.....	18' 6"	Approx. Hull Weight.....	1536 lbs	1611 lbs
Deck Width.....	8' 6"	Person Capacity.....	9 / 1197 lbs	10 / 1366 lbs
Pontoon Diameter.....	23" or 25"			
Pontoon Gauge.....	0.08"			

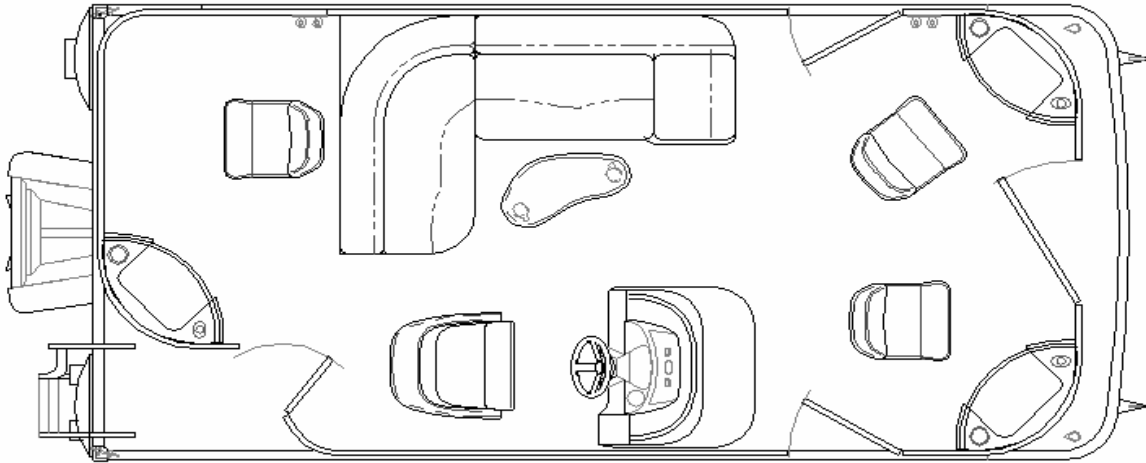

## Standard Features

- 1 Stern Fish Seat
- 2 Bow Fishing Seats
- 23" Pontoons
- 24 Gallon Transom Fuel Tank
- 4 Pole Rod Holder**
- 6" Stainless Steel Cleats
- 8.5' x 10' Bimini w/Boot - Surlast**
- Anodized, Raised Rails for Drainage
- Bimini Trailing Struts
- Captain's Seat w/ Slider / Swivel
- Fire Extinguisher
- Full length skirting**
- High Performance Palm Carpet**
- Kidney table**
- Playpen Cover - Surlast**
- Port Bow Livewell**
- Rail system - Angled top rail verticals**
- Seat hinges powder coated Java**
- Stainless Deck Bolts
- Stainless Steel Corner Castings
- Stainless Steel Ring Cup holders**
- Starboard Bow Storage**
- Stern Entry Platform & Ladder
- Stern Storage Box**
- Underdeck Spray Deflectors
- Upgraded Graphics Package in Java**

## Console Features:

- 12 Volt Receptacle (15 Amp)
- Majestic Burl Dash**
- Faria Gauges
- One piece fiberglass console**
- Instrumentation Includes:
  - Tach, Fuel & Trim Gauges
- Lockable Console Door
- Rocker Switches w/dash mounted breakers
- Soft Cooler
- Sony GT Series CD - MP3, 4 speakers**
- w/ color matched speaker grills**
- Tiger polished steering wheel**
- Windshield - Low Profile**