



OPERATOR'S MANUAL

HWH® COMPUTER-CONTROLLED 2000 SERIES LEVELING SYSTEM

FEATURING:

Touch Panel Leveling Control

BI-AXIS® Hydraulic Leveling

Kick Down Jacks

*One or Two Single Cylinder Room Extensions
(Room Locks and Air Seal)*

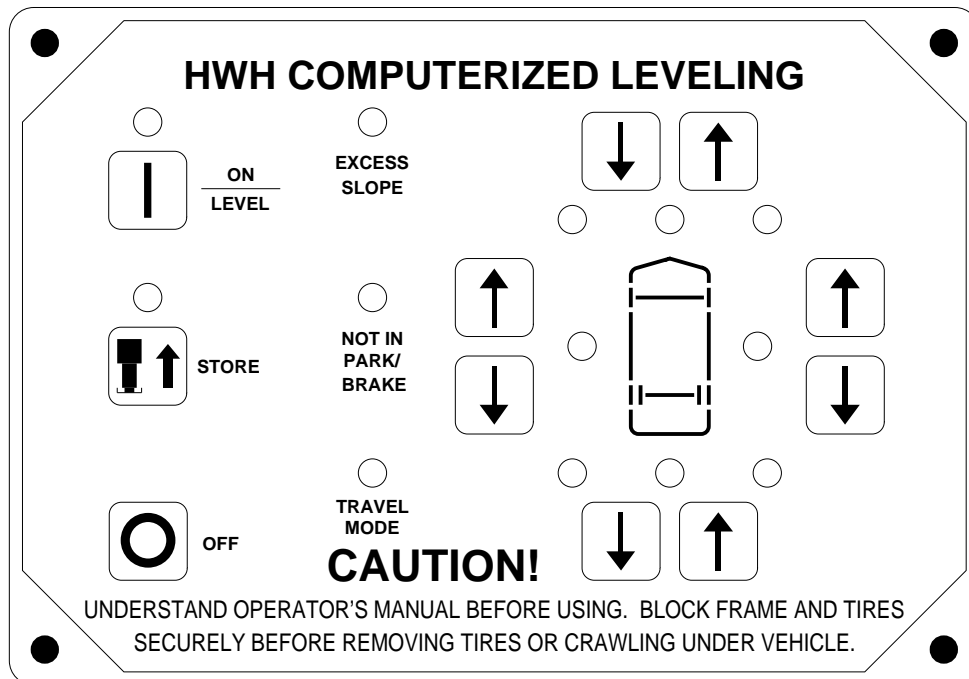

HWH CORPORATION

(On I-80, Exit 267 South)

2096 Moscow Road | Moscow, Iowa 52760

Ph: 800/321-3494 (or) 563/724-3396 | Fax: 563/724-3408

www.hwh.com

OPERATOR'S MANUAL

CAUTION !

READ THE ENTIRE OPERATOR'S MANUAL BEFORE OPERATING.

BLOCK FRAME AND TIRES SECURELY BEFORE CRAWLING UNDER VEHICLE. DO NOT USE LEVELING JACKS OR AIR SUSPENSION TO SUPPORT VEHICLE WHILE UNDER VEHICLE OR CHANGING TIRES. VEHICLE MAY DROP AND OR MOVE FORWARD OR BACKWARD WITHOUT WARNING CAUSING INJURY OR DEATH.

KEEP ALL PEOPLE CLEAR OF THE VEHICLE WHILE LEVELING SYSTEM AND ROOM EXTENSIONS ARE BEING OPERATED.

KICK-DOWN JACKS MAY ABRUPTLY SWING UP WHEN THE FOOT OF THE JACK CLEARS THE GROUND OR WHEN THE JACK REACHES FULL EXTENSION.

NEVER PLACE HANDS OR OTHER PARTS OF THE BODY NEAR HYDRAULIC LEAKS. OIL MAY PENETRATE THE SKIN CAUSING INJURY OR DEATH.

WEAR SAFETY GLASSES WHEN INSPECTING OR SERVICING THE SYSTEM TO PROTECT EYES FROM DIRT, METAL CHIPS, OIL LEAKS, ETC. FOLLOW ALL OTHER APPLICABLE SHOP SAFETY PRACTICES.

IF THE VEHICLE IS EQUIPPED WITH KICK-DOWN STYLE JACKS, DO NOT OVER EXTEND THE REAR JACKS. IF THE WEIGHT OF THE VEHICLE IS REMOVED FROM ONE OR BOTH REAR WHEELS, THE VEHICLE MAY ROLL FORWARD OR BACKWARD OFF OF THE JACKS.

IMPORTANT: IF VEHICLE IS EQUIPPED WITH A ROOM EXTENSION, READ ROOM EXTENSION SECTION BEFORE OPERATING LEVELING SYSTEM.

HOW TO OBTAIN WARRANTY SERVICE

THIS IS NOT TO BE INTERPRETED AS A STATEMENT OF WARRANTY

HWH CORPORATION strives to maintain the highest level of customer satisfaction. Therefore, if you discover a defect or problem, please do the following:

FIRST: Notify the dealership where you purchased the vehicle or had the leveling system installed. Dealership management people are in the best position to resolve the problem quickly. If the dealer has difficulty solving the problem, he should immediately contact the Customer Service Department, at HWH CORPORATION.

SECOND: If your dealer cannot or will not solve the problem, notify the Customer Service Department:
HWH CORPORATION 2096 Moscow Rd. Moscow IA. 52760
(563) 724-3396 OR 800-321-3494. Give your name and address, coach manufacturer and model year, date the

coach was purchased, or the date of system installation, description of the problem, and where you can be reached during business hours (8:00 a.m. till 5:00 p.m. c.s.t.). HWH CORPORATION personnel will contact you to determine whether or not your claim is valid. If it is, HWH CORPORATION will authorize repair or replacement of the defective part, either by appointment at the factory or by the authorization of an independent service facility, to be determined by HWH CORPORATION, or at the HWH CORPORATION factory, unless prior written approval has been obtained from proper HWH CORPORATION personnel.

THIRD: If unable to contact HWH CORPORATION call Trail Wagons during regular business hours (8:00 AM till 5:00 PM). After hours call Jason Schmidt at (509) 949-0173 or Mike Underwood at (509) 930-2072.

CONTROL IDENTIFICATION

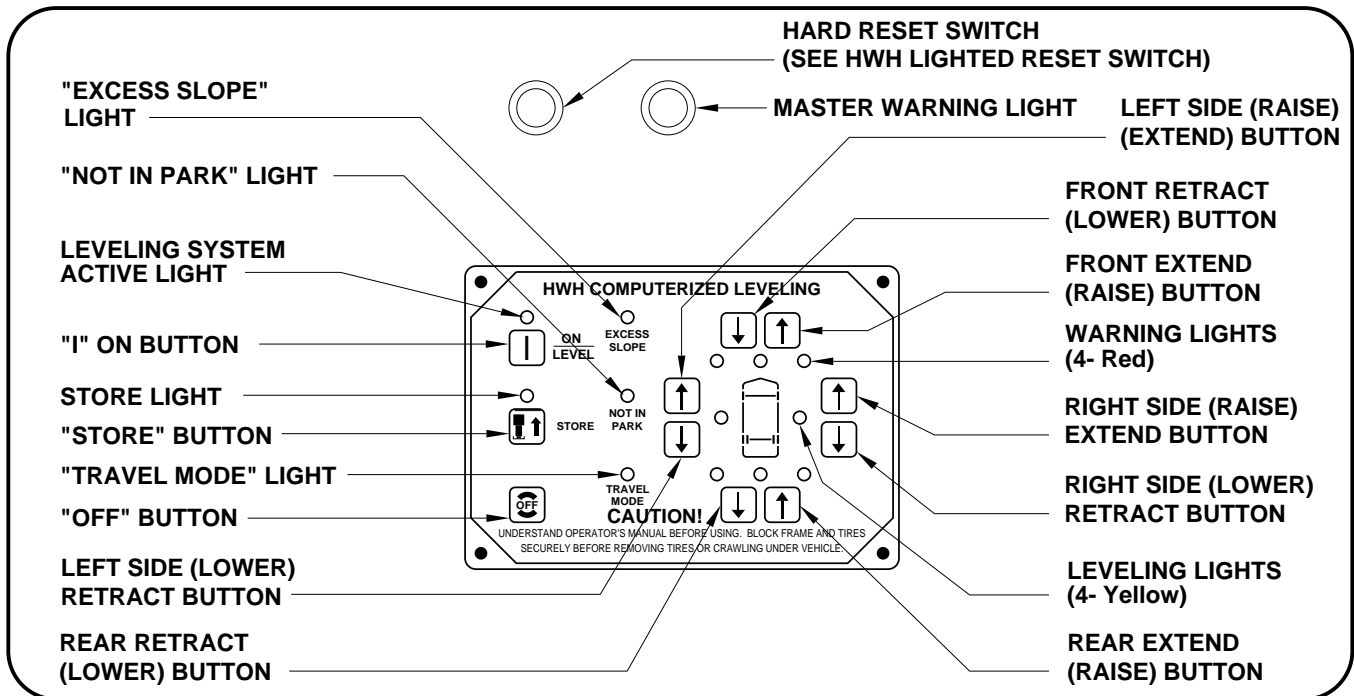

CONTROL FUNCTIONS

CONTROLS

"I" BUTTON: This is the ON button and automatic operation button. The vehicle ignition must be in the "ON" or "ACC" position.

"STORE" BUTTON: This button is used to automatically retract the jacks. The Leveling System must be ON to use the "STORE" button.

"OFF" BUTTON: This button will turn the Leveling System OFF and stop any Leveling System operations.

UP ARROWS (RAISE BUTTONS): These momentary buttons are used for manually extending the leveling jacks. Sides or ends of the vehicle will raise while these buttons are pushed.

DOWN ARROWS (LOWER BUTTONS): These momentary buttons are used for manually retracting the leveling jacks. Sides or ends of the vehicle will lower while these buttons are pushed.

INDICATOR LIGHTS

LEVELING LIGHTS: The four yellow indicating lights are level sensing indicators. When a yellow light is on, it indicates that its side or end of the vehicle is low. No more than two lights should be on at the same time.

STORE LIGHT: This light will flash when the system is in the STORE mode.

WARNING LIGHTS: The four red lights surrounding the yellow level indicators are jack WARNING lights. They are functional when the ignition is in the "ON" or "ACC" position. A lit WARNING light indicates that jack is in the vertical position.

"EXCESS SLOPE" LIGHT: This indicator will light when the leveling system cannot level the vehicle.

"NOT IN PARK/BRAKE" LIGHT: This indicator will light when the ON button is pushed and the hand/auto park brake is not set. The "NOT IN PARK/BRAKE" light will go out when the ON button is released.

"TRAVEL MODE" LIGHT: This indicator light will be ON when the ignition is ON, when the jacks are retracted, when the room is retracted and locked, and there are no red WARNING lights ON.

MASTER WARNING LIGHT: This is a light mounted in the overhead separate from the touch panel. It will be ON when any one or more jacks are vertical, when the room is extended or unlocked and the ignition is "ON".

CONTROL IDENTIFICATION

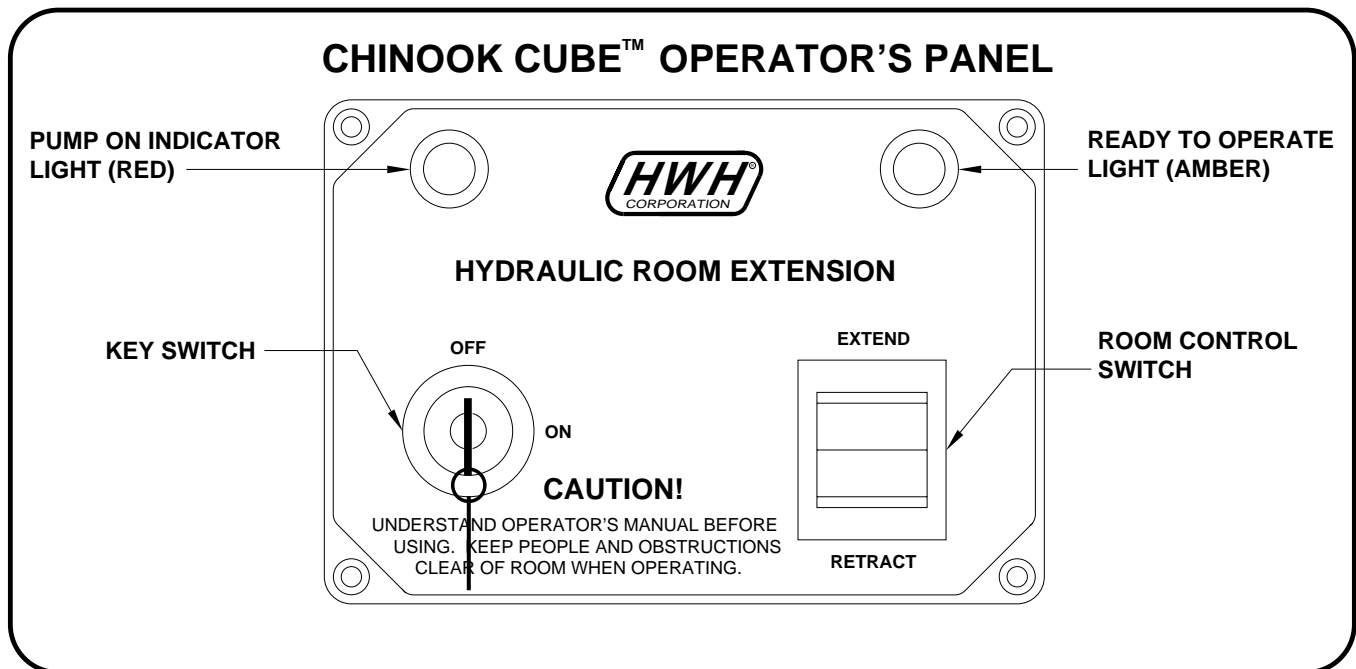

CONTROL FUNCTIONS

KEY SWITCH: The KEY SWITCH controls power to the ROOM CONTROL SWITCH. When the KEY SWITCH is in the "ON" POSITION the room can be operated, and the key cannot be removed. When the KEY SWITCH is in the "OFF" position the room cannot be operated, and the key can be removed.

NOTE: Any time the KEY SWITCH is ON, the network will be active and will not power down.

ROOM CONTROL SWITCH: The ROOM CONTROL SWITCH is a two position momentary switch. Pressing the switch in the EXTEND POSITION will extend the room. Pressing the switch in the RETRACT POSITION will retract the room. Releasing the ROOM CONTROL SWITCH will halt the operation of the room.

PUMP ON INDICATOR LIGHT: This light will be on when the pump is running.

READY TO OPERATE LIGHT: This light will flash for 20 seconds while the air seal deflates, after the KEY SWITCH is turned on. It will then glow steady. The room cannot be extended or retracted if this light is flashing.

If the "EXCESS SLOPE" light on the leveling system control panel is on, the READY TO OPERATE light will flash when the room control switch is pushed to "EXTEND". The room will not extend. The room will retract if the room control switch is pushed to "RETRACT".

If the PARK BRAKE is not set, the READY TO OPERATE light will not turn on and flash when the KEY SWITCH is turned "ON".

If a leveling function of the Leveling System is in use, MANUAL or AUTOMATIC operation, the READY TO OPERATE light will flash if the KEY SWITCH is in the "ON" position. The room will not operate. The room can be operated if the Leveling System is in the "STORE" mode.

OPERATING PROCEDURES

GENERAL INSTRUCTIONS

Maintain adequate clearance in all directions for vehicles, room extensions, doors, steps, etc.. Vehicle may move in any direction due to raising or lowering of vehicle during leveling, settling of vehicle, equipment malfunction, etc..

If parking on soft ground or asphalt paving, a wood block or pad should be placed under each jack.

Park with the front of the vehicle facing down hill if possible. Care must be taken not to raise the rear of the vehicle to high or the vehicle may roll forward or backward off the jacks.

The MASTER WARNING LIGHT will be ON if a jack is in the vertical position or if a room in or room lock limit switch is not made, if the ignition is in the "ON" position.

CAUTION: DO NOT MOVE THE VEHICLE IF A ROOM IS EXTENDED.

Press the "OFF" button to stop operation of the Leveling System.

If the Park Brake is not set, the Leveling System cannot be turned ON and the room extension will not operate.

If a ROOM CONTROL SWITCH is being pushed, the Leveling System can not be operated. If any Leveling System leveling function is being operated, no room control switch will work. The room can be operated if the Leveling System is in the STORE mode.

HWH LIGHTED RESET SWITCH

The HWH lighted reset switch is located on the vehicle overhead panel. If there is a failure at any time in the HWH CAN network, the network will shut down. The leveling system and all room extensions will not operate. If the ignition is off, no indicator lights will come on. If the ignition is in the "ON" or "ACC" position, the lighted reset switch and the MASTER WARNING Light will come on.

If the lighted reset switch is on, the switch must be pushed before any room or the leveling system can be operated.

If the operation of the room is halted and the lighted reset switch is on, there may be a problem with an unlock limit switch. The room mechanism should be checked and repaired before trying to operate that room again. Operating a room with a lock extended may cause extensive damage to the room.

A network problem with one room will not inhibit the use of the other rooms or leveling system after the reset switch is pushed.

A network problem with the leveling system will not inhibit the use of the room extensions after the reset switch is pushed.

If the lighted reset switch will not go out when pushed, there is a problem with the central control module of the network system. No rooms or the Leveling System will operate.

OPERATING PROCEDURES

PREPARATION FOR TRAVEL

Before traveling the red jack warning lights must be off and the "TRAVEL MODE" light must be on. If lights are not correct for travel, retract jack as described in the JACK RETRACTION section.

Check that all room extensions are fully retracted and locked. The green "TRAVEL MODE" light on the touch panel will not be on if a room is extended or not locked. The MASTER WARNING light will be ON. (SEE ROOM RETRACT PROCEDURES)

CAUTION: DO NOT RELY SOLELY UPON THE WARNING LIGHTS. IT IS THE OPERATOR'S RESPONSIBILITY TO CHECK THAT ALL JACKS ARE IN THE STORE/TRAVEL POSITION AND THAT THE ROOM EXTENSION IS FULLY RETRACTED BEFORE TRAVELING.

If the jacks and room extension are fully retracted but a red WARNING light is lit or the green "TRAVEL MODE" light is not lit, the system needs to be serviced.

NOTE: A jack in the vertical position or an extended or unlocked room can turn the green "TRAVEL MODE" light off and turn the MASTER WARNING light on.

If the jacks cannot be retracted according to the JACK RETRACTION section, retract the jacks according to the MANUAL JACK RETRACTION section. The system should then be checked.

AUTOMATIC HYDRAULIC LEVELING

1. Place the transmission in the recommended position for parking the vehicle and set the parking brake. Turn the ignition to the "ACCESSORY" or "ON" position.

2. Press the "I" button to enter the hydraulic operation mode. The LEVELING SYSTEM ACTIVE light will glow steady.

3. Press the "I" button a second time. The LEVELING SYSTEM ACTIVE light will start to flash. One at a time the jacks will swing to the vertical position. The red WARNING light for each jack will come on as its respective jack becomes vertical. At this time, the operator may want to check the jacks and place a pad under each jack if the ground will not support the vehicle.

NOTE: After trying to extend the jacks to the vertical position, the panel will turn off if all four red WARNING lights are not lit.

4. Press the "I" button a third time. The LEVELING SYSTEM ACTIVE light will start to flash. The system will automatically extend the jacks according to lit yellow LEVELING LIGHTS to level the vehicle and then stabilize the vehicle by extending any remaining jacks until they touch the ground lifting the vehicle slightly. After the system has finished leveling and stabilizing, it will automatically shut off.

EXCESS SLOPE SITUATION: In the event that the jacks are unable to level the coach, the "EXCESS SLOPE" indicator light will come on. The pump will shut off. The system will shut off. The system will NOT stabilize the vehicle if the "EXCESS SLOPE" light comes on. Store the jacks according to the JACK RETRACTION section. Move the vehicle to a more level position or level the vehicle as close as possible according to the MANUAL HYDRAULIC OPERATION section.

NOTE: The Chinook Cube™ can not be extended if the "EXCESS SLOPE" light is on, but it can be retracted.

The "EXCESS SLOPE" light will be on whenever the network is active until the vehicle is leveled with all yellow LEVEL INDICATOR lights off.

5. Turn the vehicle ignition switch to the "OFF" position.

OPERATING PROCEDURES

CHINOOK CUBE™ EXTEND PROCEDURE

The vehicle should be leveled before extending a room.

1. The park brake must be set for the room to be operated. If the "EXCESS SLOPE" light on the touch panel is on, the room cannot be extended.

IMPORTANT: The Chinook Cube™ should not be extended unless the vehicle is level. If the "EXCESS SLOPE" light is ON, the vehicle must be re-leveled so all yellow LEVEL indicator lights on the touch panel are OFF before the room can be extended. If any of the four yellow LEVEL indicator lights cannot be put out, the vehicle should be moved to a more level location before using the room extension.

CAUTION: KEEP PEOPLE AND OBSTRUCTIONS CLEAR OF ROOM WHEN OPERATING.

NOTE: Make sure there is adequate clearance to fully extend the room and that all storage doors are closed.

2. Insert the KEY into the KEY SWITCH on the room extension operator's panel and turn it to the "ON" position. The READY TO OPERATE light will flash. When the amber light is on steady the room can be operated.

NOTE: Anytime the KEY SWITCH is on, the room air seal will deflate.

NOTE: If the Leveling System is being operated, the room will not extend. If the room panel KEY SWITCH is on, the "READY TO OPERATE" light will flash while the Leveling System is being operated.

3. To extend the Chinook Cube™, push and hold the ROOM CONTROL SWITCH in the extend position. The red PUMP ON light will come on. There may be a delay of several seconds (no more than 10 seconds) before the PUMP ON light comes on after the switch is pushed. When the room is fully extended, the pump will automatically shut off. The red PUMP ON light will go out. Do not release the ROOM CONTROL SWITCH, until the red PUMP ON light goes out. **If the red PUMP ON light remains on 30 seconds after the room is fully extended release the room control switch.**

NOTE: Under normal operation of the room, the direction of movement should not be reversed. If the movement of the room must be reversed, do not try to re-extend the room until the room has been fully retracted.

IMPORTANT: IF EITHER SIDE OF THE ROOM STOPS MOVING, RELEASE THE ROOM CONTROL SWITCH IMMEDIATELY. THE ROOM OPERATION WILL HALT. DO NOT FORCE THE ROOM. DO NOT REVERSE DIRECTION OF THE ROOM. BINDING OF ROOM CAN CAUSE ROOM DAMAGE. CONTACT HWH CORPORATION CUSTOMER SERVICE FOR ASSISTANCE.

NOTE: The READY TO OPERATE light will flash when the room control switch is pushed if the "EXCESS SLOPE" light on the Leveling System panel is ON. The room will not extend.

4. Turn the KEY SWITCH to the "OFF" position and remove the key. The READY TO OPERATE light will go out. The air seal will inflate.

NOTE: If the KEY SWITCH is left "ON" the air seal will not inflate and the Network will stay active and not power down.

OPERATING PROCEDURES

CHINOOK CUBE™ RETRACT PROCEDURE

CAUTION: KEEP PEOPLE AND OBSTRUCTIONS CLEAR OF ROOM WHEN OPERATING.

1. The park brake must be set for the room to be operated.

IMPORTANT: It is recommended to retract room extensions before retracting the jacks.

2. Insert the KEY into the KEY SWITCH on the room extension operator's panel and turn it to the "ON" position. The air seal will deflate. The READY TO OPERATE light will flash. When the amber light is on steady the room can be operated.

NOTE: If the Leveling System is being operated, the room will not retract. If the room panel KEY SWITCH is ON, the READY TO OPERATE light will flash while the Leveling System is being operated.

3. To retract the Chinook Cube™, push and hold the ROOM CONTROL SWITCH in the "RETRACT" position. The red PUMP ON light will come on. When the room is fully retracted, the pump will automatically shut off. The red PUMP ON light will go out. Do not release the ROOM CONTROL SWITCH until the red PUMP ON light goes out. **If the red PUMP ON light remains on 30 seconds after the room is fully retracted release the room control switch.**

NOTE: (FOR ROOMS WITH HWH LOCKS) If the ROOM CONTROL SWITCH is released before the red PUMP ON light goes out, the room may not be properly locked.

NOTE: Under normal operation the direction of movement should not be reversed. If the movement of the room must be reversed, do not try to retract the room until the room has been fully extended.

IMPORTANT: IF EITHER SIDE OF THE ROOM STOPS MOVING, RELEASE THE ROOM CONTROL SWITCH IMMEDIATELY. THE ROOM OPERATION WILL HALT. DO NOT FORCE THE ROOM. DO NOT REVERSE DIRECTION OF THE ROOM. BINDING OF ROOM CAN CAUSE ROOM DAMAGE. CONTACT HWH CORPORATION CUSTOMER SERVICE FOR ASSISTANCE.

4. Turn the KEY SWITCH to the "OFF" position and remove the key. The READY TO OPERATE light will go out. The air seal will inflate.

NOTE: If the KEY SWITCH is left "ON" the air seal will not inflate and the Network will stay active and not power down.

IN THE EVENT OF THE FAILURE OF THE ROOM TO RETRACT, CONTACT HWH CORPORATION CUSTOMER SERVICE AT 1-800-321-3494 FOR ASSISTANCE OR TRAIL WAGONS AT 800-552-8886 OR AFTER HOURS JASON SCHMIDT AT (509) 949-0173 OR MIKE UNDERWOOD AT (509) 930-2072.

OPERATING PROCEDURES

JACK RETRACTION

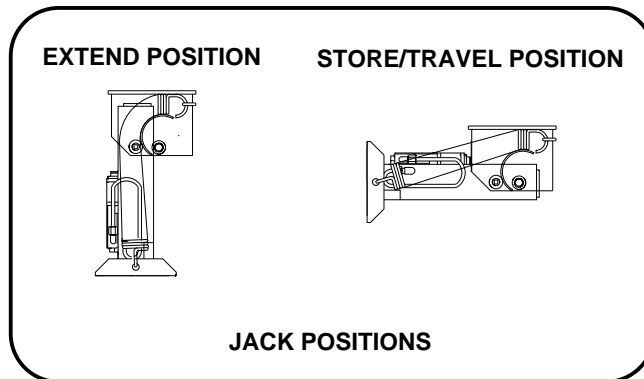

CAUTION: THE OPERATOR MUST BE SURE THAT THERE ARE NO OBJECTS UNDER THE VEHICLE AND THAT ALL PEOPLE ARE CLEAR OF THE VEHICLE.

1. Turn the ignition switch to "ON", "ACC", or start the engine. Press the "I" button one time. The "I" indicator light will glow steady.

2. Press the "STORE" button. The store indicator light will flash. As each jack retracts, its red WARNING light will go out. The vehicle can be moved as soon as the red WARNING lights are out and the green "TRAVEL" light is on, providing the jacks are in the STORE/TRAVEL position.

IMPORTANT: DO NOT interrupt power to the leveling system while the "STORE" indicator light is blinking. DO NOT push the "OFF" button. The system must be allowed to completely finish the store mode. If the engine was started before putting the system in the store mode, the vehicle may be moved when the jacks are in the STORE/TRAVEL position. This will not interrupt the store procedure.

CAUTION: DO NOT RELY SOLELY UPON THE WARNING LIGHTS. IT IS THE OPERATOR'S RESPONSIBILITY TO CHECK THAT ALL JACKS ARE IN THE STORE/TRAVEL POSITION BEFORE TRAVELING.

3. The system will automatically shut down six minutes after the four individual red "WARNING" lights are out. If any one red "WARNING" light does not go out, the system will continue to store for thirty (30) minutes, then shut down regardless of the "WARNING" lights condition.

NOTE: If the ROOM CONTROL SWITCH is pushed while the Leveling System is in the "STORE" mode, the STORE procedure is interrupted until the ROOM CONTROL SWITCH is released. If the four red WARNING lights are all out, the STORE light will continue to blink for six minutes, then the system will shut off.

4. If jacks cannot be retracted by the above procedure see MANUAL JACK RETRACTION Section.

MANUAL HYDRAULIC OPERATION

1. Place transmission in the recommended position for parking the vehicle, and set the parking brake. Turn the ignition to the "ACCESSORY" or "ON" position.

2. Press the "I" button. The indicator light will glow steady.

3. Press the "I" button a second time. The hydraulic indicator light will start to flash. One at a time, the jacks will swing to the vertical portion. The four red WARNING lights will be on. Place pads under the jack feet if the ground will not support the vehicle on the jacks.

4. The vehicle may be leveled using the manual EXTEND buttons on the right half of the panel. If a yellow LEVEL SENSING light is on, that side or end of the vehicle is low. Jacks will extend (or retract) in pairs to raise (or lower) a side or end of the vehicle.

Level the vehicle side to side, if necessary, before leveling the vehicle front to rear. Any jack not used for leveling can be extended to the ground. This provides additional stability against wind and activity in the vehicle.

IMPORTANT: Do not continue to push an EXTEND button for more than ten (10) seconds after that pair of jacks are fully extended.

5. When leveling is completed, push the "OFF" button on the leveling panel and turn the ignition switch to the "OFF" position.

OPERATING PROCEDURES

MANUAL JACK RETRACTION (4 Jack Systems with Valve Release Nuts)

NOTE: Use the Valve Release Nuts for retracting only if the "STORE" button on the control panel will not retract the jacks for travel.

CAUTION: KEEP AWAY FROM THE WHEELS, DO NOT CRAWL UNDER THE VEHICLE, KEEP A SAFE DISTANCE IN FRONT AND REAR OF THE VEHICLE. THE VEHICLE MAY DROP AND/OR MOVE FORWARD OR BACKWARD WITHOUT WARNING AS THE VALVE RELEASE IS OPERATED.

1. Locate the (4) valve release nuts on the solenoid valves. The solenoid valves are located on the power unit/valve assembly.
2. Allow clearance for the vehicle to lower.
3. Retract the front jacks by opening the two center valves. Slowly turn the valve release nuts counter clockwise using the 1/4" nut driver supplied.
4. Retract the rear jacks by opening the two outer valves. Slowly turn the valve release nuts counter clockwise using the 1/4" nut driver supplied.

IMPORTANT: Only open the valves enough to retract the jacks. DO NOT turn the release nuts more than 4 and 1/2 turns. Turning the nuts more could damage the valves.

NOTE: Prior to APRIL 2002 a 1/4" Nut Driver was sent with the Operators Manual. As of APRIL 2002 the 1/4" Nut Driver has been incorporated into the Breather Cap. See the back page of this manual for further info.

5. Check that all four jacks are now retracted.
6. Close the valves by turning the valve release nuts clockwise.

IMPORTANT: Once the valve release nuts are snug, DO NOT tighten the nuts past this point as internal damage may occur to the solenoid.

7. The system should now be repaired before using again.

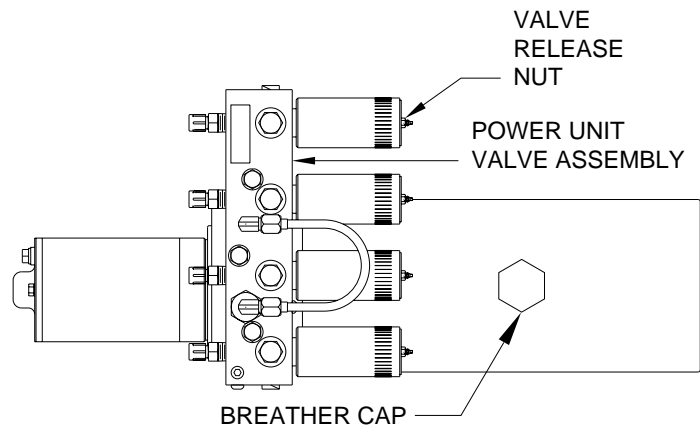

MAINTENANCE

ELECTRICAL SYSTEM

The batteries should be in good condition and **fully charged**. Weak batteries can cause erratic operation. Battery cable terminals and battery posts and connections should be kept clean.

All electrical connections, especially ground connections, should be clean, tight, free from corrosion and protected from weathering.

UNUSUAL CONDITIONS

If driving conditions are unusually muddy, the jacks may become caked or clogged with mud. This condition may hamper the proper operation of the leveling system. This problem may be prevented or remedied by cleaning off each leveling jack if they become excessively muddy.

Do not move the vehicle while the leveling jacks are still in contact with the ground. Retract the jacks according to the "JACK RETRACTION" Section and then visually check to see if the leveling jacks have returned to the STORE/TRAVEL position.

In wet or icy weather leveling jacks may become encrusted with ice. This may cause the leveling system to function improperly. To eliminate this problem, periodically check the leveling jacks and break loose any ice which may be causing improper operation.

NOTE: All major components of the system can be replaced with rebuilt parts or can be sent to HWH CORPORATION to be rebuilt, when the system is out of warranty.

OPERATIONAL CHECK

Review the operator manual and run the system in the automatic and manual mode. Note any abnormal operation.

Review the JACK RETRACTION Section.

Check that all lights work according to the INDICATOR LIGHT section. Correct function of the four red WARNING lights is essential to the correct operation of the system.

Make sure the jacks will fully retract to the store position. Jacks should not interfere with any part of the vehicle when in the store position.

Check that the vehicle is level when all the yellow LEVEL indicator lights are out.

With the jacks extended, check that the jacks can be retracted using the "T" handles on the solenoid valves. Refer to the MANUAL JACK RETRACTION Section.

NOTE: The level sensing unit has an accuracy tolerance of + or - 1 inch side to side, and + or - 5.4 inches front to rear on a 36 foot vehicle.

"NOT IN PARK/BRAKE" CHECK

CAUTION: WHEN MAKING THIS CHECK, BLOCK THE VEHICLES WHEELS SECURELY SO THE VEHICLE CAN NOT ROLL FORWARD OR BACKWARD.

Release the parking brake. The LEVELING SYSTEM ACTIVE light should go out. Push the ON button. The "NOT IN PARK/BRAKE" light should come on while the ON button is being pushed. Set the parking brake. Push the ON button. The system should turn ON.

Set the park/brake. Switch the ignition to "ACCESSORY" or "ON" position. Press the hydraulic button one time.

NOTE: If any of the pervious checks or inspections reveal a problem or if there are other problems or questions, consult a qualified RV repair center, your vehicle or coach manufacturer, or HWH CORPORATION for service or repair.

BREATHER CAP - DIPSTICK - 1/4" NUT DRIVER

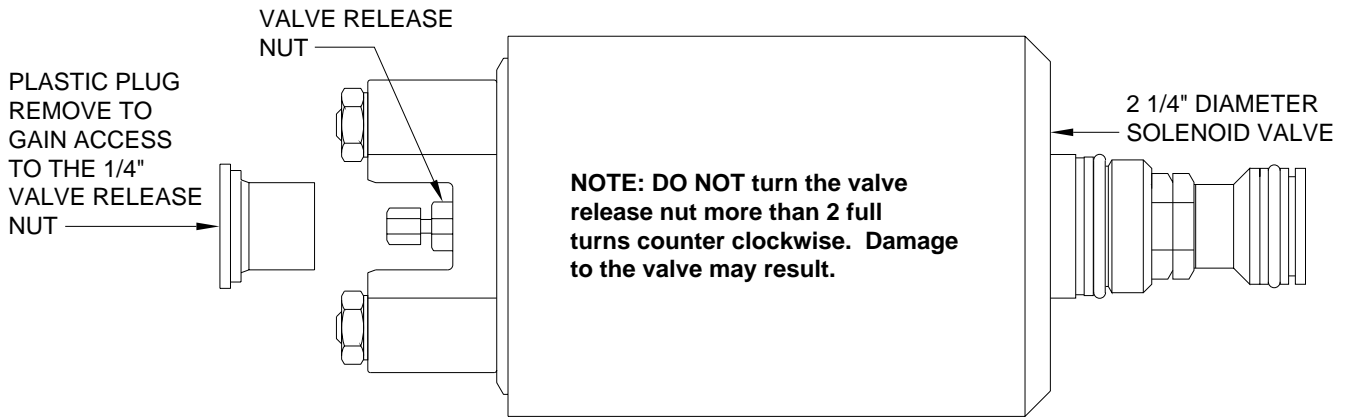
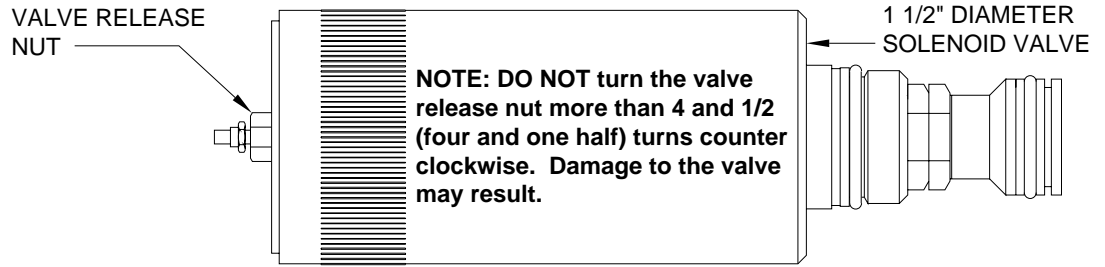

NOTE: THE BREATHER CAP IS LOCATED ON THE TOP SIDE OF THE POWER UNIT RESERVOIR.

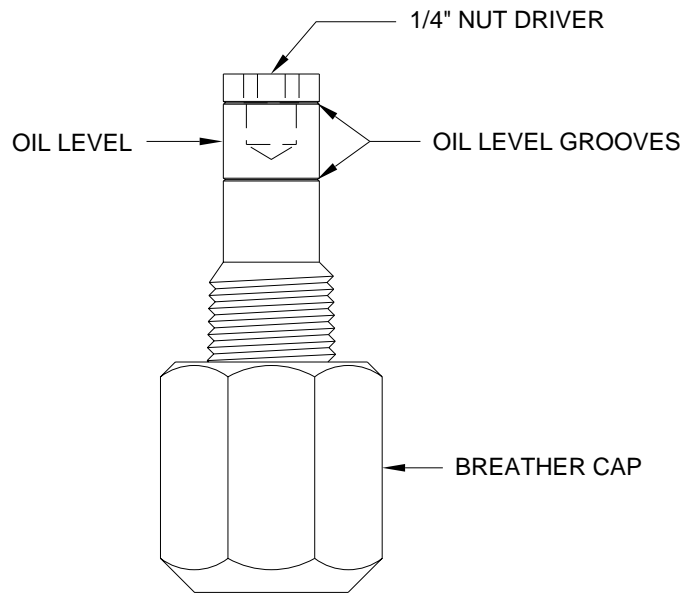

IMPORTANT: PRIOR TO REMOVING THE BREATHER CAP, EITHER TO CHECK THE OIL LEVEL OR TO USE THE 1/4" NUT DRIVER, CLEAN ANY DEBRIS FROM THE TOP OF THE RESERVOIR. BEFORE RETURNING THE BREATHER CAP TO THE RESERVOIR, REMOVE ANY PAINT CHIPS OR OTHER DEBRIS FROM THE DIPSTICK INCLUDING DEBRIS INSIDE THE 1/4" NUT DRIVER.